

名称 Name	ネジ込揚程式安全弁 Screwed lift type safety valve				図面番号 Drawing No.	130311D	
型式 Type	SD120-S	呼び径 Nominal Dia.		設定圧力 Set Press.	MPa G	吹止り圧力 Reseating Press.	MPa G
流体名 Fl Name		吹出温度 Blowing Temp.	°C	常用圧力 Operating Press.	MPa G	作成 Drawn	検図 Check
吹下り Blow Down		バネ設定圧力 Spring Set Press.	MPa G	耐圧試験 Hyd. Press.	MPa G	年月日 Date	

備考 Remarks	-----	

作業番号 Working No.	工事番号 Job No.
---------------------	-----------------

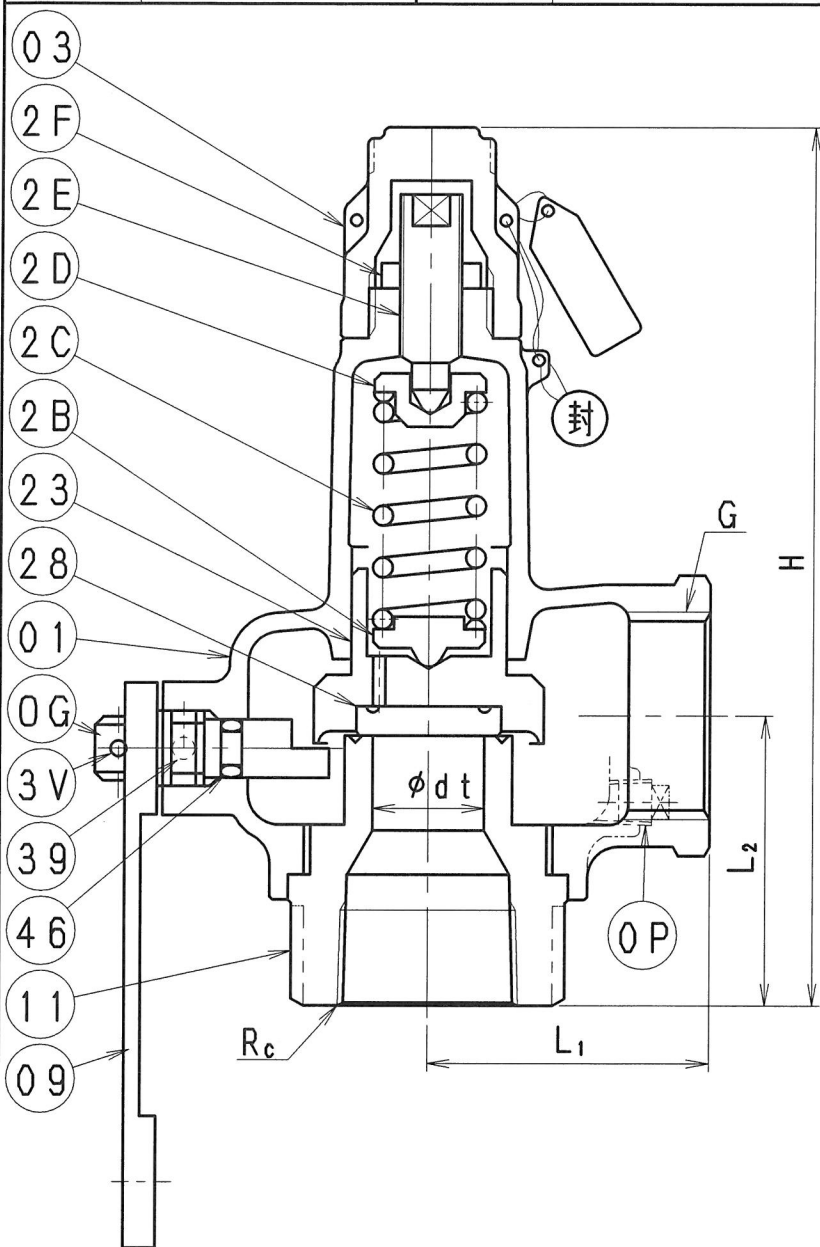

品番 No	部品名 Parts name	数量 Q'ty	材質 Material
01	弁箱 BODY	1	SCS 13A
11	弁座 VALVE SEAT	1	SCS 13A
28	ディスクパッキン DISC PACKING	1	PTFE
23	弁胴 HOLDER	1	SCS 13A
2B	バネ受け SPRING SEAT	1	SUS 304
2D	バネ押し SPRING SEAT	1	SUS 304
2C	バネ SPRING	1	SUS 304
2E	調整ネジ ADJUST SCREW	1	SUS 304
2F	止メナット LOCK NUT	1	SUS 304
03	キャップ CAP	1	SCS 13A
0G	レバ軸 LEVER SHAFT	1	SUS 304
46	Oリング O-RING	1	VITON
39	スプリングピン SPRING PIN	1	SUS 304
3V	ピン PIN	1	SUS 304
09	レバ LEVER	1	SCS 13A
0P	プラグ PLUG	1	SUS 304

UNIT (mm)

呼び径 NOMINAL DIA.	のど径 BORE OF THROAT d _t	リフト LIFT L	取付寸法 PIPING SIZE		面間寸法 CENTER TO FACE		H	有効面積(A) EFFECTIVE DISCHARGE AREA
			R _c	G	L ₁	L ₂		
15	15	1.0	R _c 1/2	G 3/4	35	39	125	47.1
20	20	1.4	R _c 3/4	G 1	45	43	145	87.9
25	25	1.7	R _c 1	G 1-1/4	50	51	165	133.5